

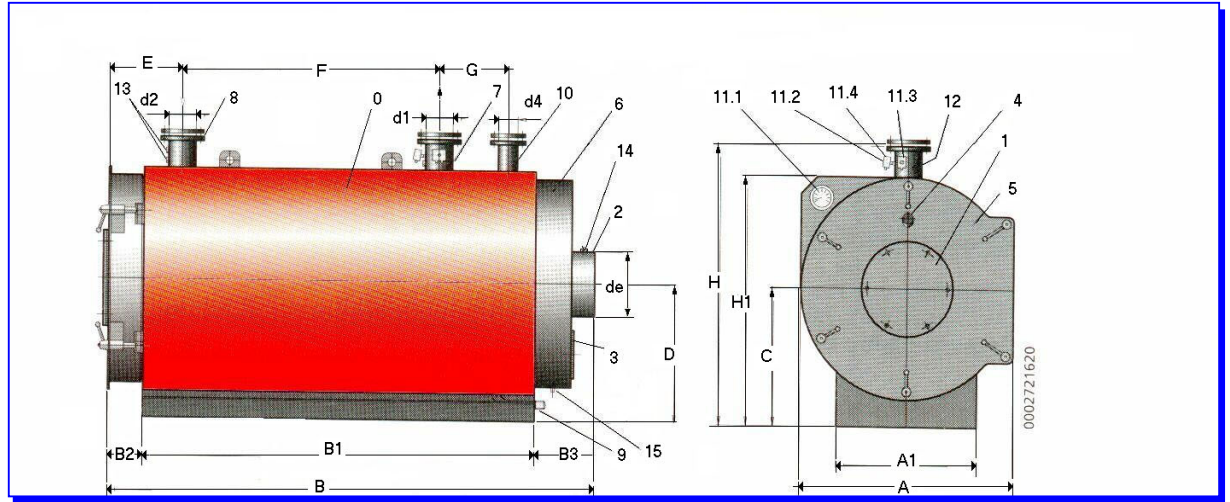



Calderas Industriales S.P.A  
 Las Higueras N°2569 – La Pintana - Santiago -Chile  
 E-mail: ventas@calderasindustriales.cl

- 0 CUERPO CALDERA
- 1 PLACA MONTAJE QUEMADOR
- 2 SALIDA DE GASES
- 3 PUERTA INSPECCION Y LIMPIEZA
- 4 MIRILLA CONTROL LLAMA
- 5 CAMARA DE HUMOS DELANTERA
- 6 CAMARA DE HUMOS POSTERIOR
- 7 SALIDA AGUA CALEFACCION
- 8 RETORNO AGUA CALEFACCION
- 9 DRENAJE
- 10 VALVULA DE ALIVIO
- 11 PANEL DE CONTROL
- 11.1 TERMOMETRO
- 11.2 TERMOSTATO DE REGULACION
- 11.3 TERMOSTATO DE REGULACION 2° EST
- 11.4 TERMOSTATO DE BLOQUEO MANUAL
- 12 SALIDA PARA TERMOSTATO AUXILIAR
- 13 COPLA PARA INSTRUMENTO SUPLEMETARIO
- 14 COPLA PARA CONTROL DE TEMP. GASES
- 15 DRENAJE CONDENSADO CAJA HUMOS TRASERA



MODELO		HW 250	HW 300	HW 350	HW 400	HW 500	HW 600	HW 700	HW 800	HW 900	HW 1000	HW1250	HW 1600	HW 2000	HW 2500	HW 3000	HW 3500	HW 4000
A	.mm	960	960	960	1170	1170	1270	1270	1370	1370	1370	1370	1460	1550	1660	1790	1910	2040
A1	.mm	890	890	890	1100	1100	1200	1200	1300	1300	1300	1300	960	1050	1160	1240	2135	2270
B	.mm	1750	1900	1700	2200	2280	2315	2385	2385	2635	2895	2895	3415	3415	3665	3765	2130	4550
B1	.mm	1240	1390	1490	1650	1730	1750	1830	1830	2080	2340	2340	2800	2850	3050	3150	3500	3850
B2	.mm	280	280	280	300	300	300	300	300	300	300	300	235	235	235	235	235	235
B3													380	380	380	380	380	380
C	.mm	560	560	560	680	680	760	760	800	800	800	800	886	930	1035	1100	1180	1250
D	.mm	790	790	790	930	930	1020	1020	1095	1095	1095	1095	886	930	1035	1100	1180	1250
E	.mm	440	440	440	440	440	440	440	440	440	440	440	485	535	535	535	590	590
F	.mm	580	730	830	970	1050	1070	1150	1150	1400	1660	1660	2020	1950	2150	2250	2400	2675
G	.mm	330	480	580	650	730	750	830	830	1080	1340	1340	350	400	400	400	450	450
H	.mm	1140	1140	1140	1345	1345	1500	1500	1600	1600	1600	1600	1810	1900	2060	2190	2335	2470
H1	.mm	1095	1095	1095	1300	1300	1455	1455	1555	1555	1555	1555	1610	1700	1860	1990	2135	2270
de	.mm	240	240	240	300	300	350	350	450	450	450	450	508	558	608	658	658	658
d1-d2	.PN 6	DN 80	DN 80	DN 80	DN 100	DN 100	DN 100	DN 100	DN 125	DN 125	DN 125	DN 125	150 PN 10	200 PN 10	200 PN 10	200 PN 10	250 PN 10	250 PN 10
d4	.PN 6	DN 50	DN 50	DN 50	DN 65	DN 65	DN 65	DN 65	DN 80	DN 80	DN 80	DN 80	PN10DN 100	PN10DN 125	PN10DN 125	PN10DN 125	PN10DN 150	PN10DN 150
PESO	Kg.	710	770	830	1075	1185	1465	1570	1570	1945	2100	2900	3280	3720	4760	5650	6440	7880